

BRAVO 3

A Tough, 3-Function Manipulator for Inspection Class Vehicles

The Bravo 3 is a dependable 3-Function manipulator that opens up new compact inspection and intervention opportunities for service providers, researchers, and other operators.

- **DEXTEROUS**
3-Function (or custom fit)
Highly Modular & Configurable
- **RUGGED**
450m Depth Rating
15kg Full Reach Lift
- **SMART**
In-Built Kinematics
Master Arm Controlled

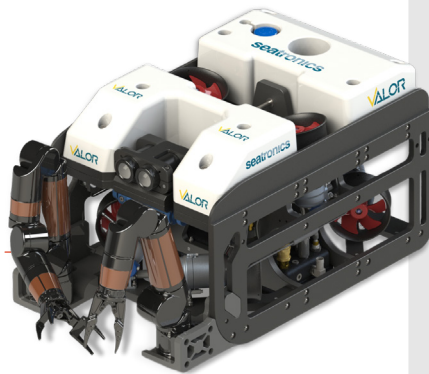

ROV & UGV Proven

NEW MK2 FEATURES

- Slip-rings in all inlines
- Increased 450m depth rating (600m rated in the future)
- High strength linear (approx. up to 10kN)
- Higher joint speed
- Increased reliability & easier maintenance

FEATURES

- Ready-built and designed for industry leading inspection-class vehicles
- All-Electric, Zero Oil
- End effectors: grabbers, probe handlers, cutters (or BYO)
- Advanced software interface with 3D visualisation
- One-click deploy/stow position
- Adjustable grab force - pick up a sea urchin or cut a cable

BE CONFIDENT

Designed to conduct tasks usually reserved for human divers, the arm's usability and responsiveness pave the way for advanced applications.

The form factor was specifically designed for industry leading inspection-class ROVs making it a ready-to-go option for existing fleets.

- **ELECTRICAL**
Voltage 24-48V
Nominal Power 60W (10kg Load)
Peak Power 150W (10kg Load)
COMS RS232/RS485/Ethernet
- **ENVIRONMENTAL**
Depth 450MSW
Temp -10°C to 35°C
Material AL6061
- **MECHANICAL**
Lift Capacity 15kg
Weight (Air) 4kg
Weight (Water) 2.6kg

Master Arm Controller Enabled
Note: Master Arm not included



Mission Specific End-Effectors | Interchange With Ease



RB-1025



RB-1055



RB-1041



RB-1043



RB-1044 SS



RB-1042



RB-1034

SPECIFICATIONS

Full-Extension Reach	410mm
Max Lift Capacity	15kg
Joint Speed	(24-48V)
End-effector Accuracy	<1cm
Linear/Grabber Force	2000N
Jaw Clamp Force	50kg
Base Joint Torque	50Nm
Wrist Torque	20Nm
Connector cable	13 Pin Ethernet Subcon (DBH13M)

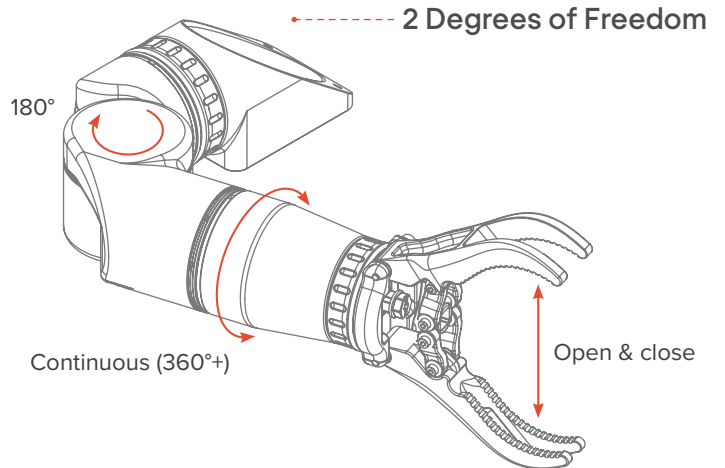

Note: Mounting Kit not included

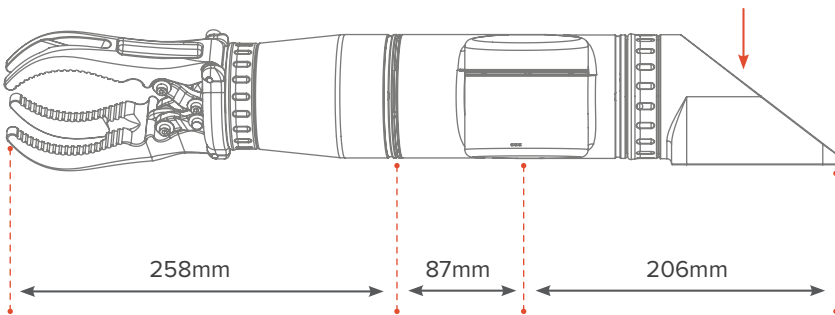

ELECTRICAL

Voltage	24-48V
Nominal Power	60W (10kg load)
Peak Power	150W (10kg load)
COMS	RS232/485/Ethernet

ENVIRONMENTAL

Depth	300MSW
Temp	-10°C to 35°C
Material	AL6061

MECHANICAL

Max Lift	15kg
Weight (Air)	4kg
Weight (Water)	2.6kgs

HIGH MOBILITY & COMPACT

TOP VIEW

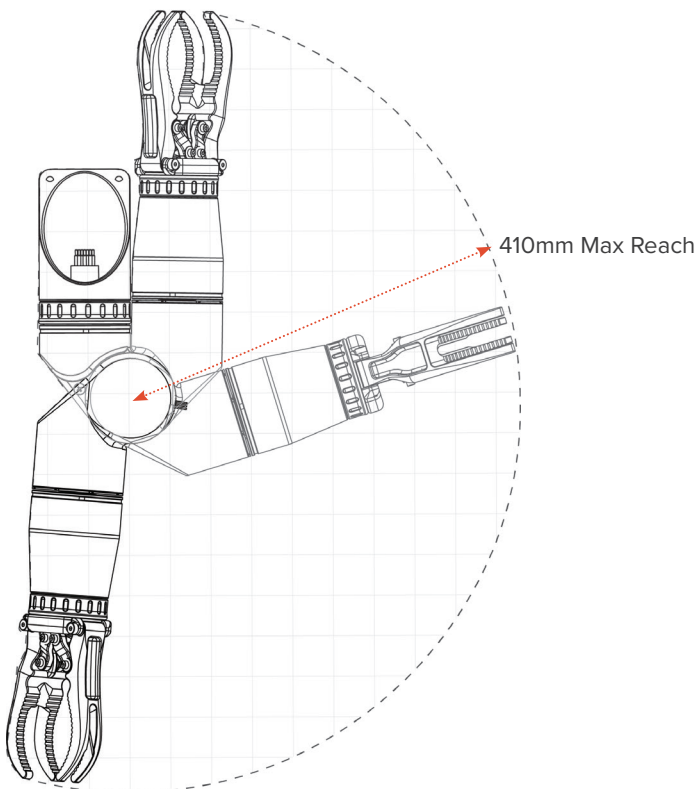

Integration Made Easy

Integrate Reach Bravo manipulators with our mounting unit, designed for simple installation on industry leading vehicles. A screw collar system lets you mount and unmount in seconds.

