

WRIST CAMERA

A wrist camera for Reach Bravo manipulators

Clear vision where it's most needed

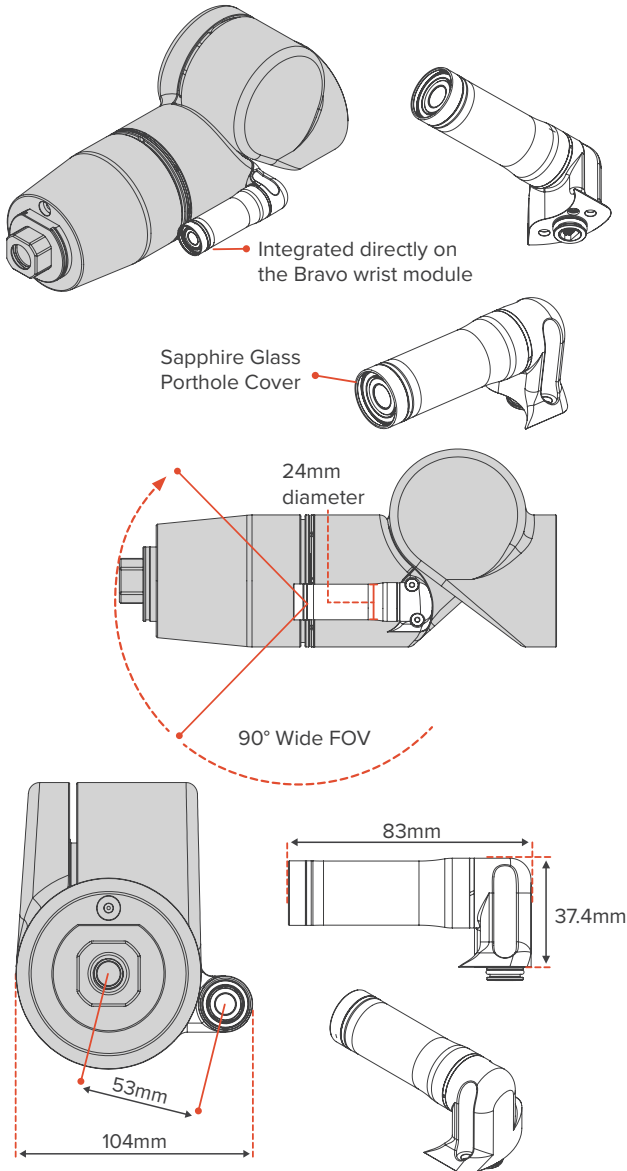

YOUR EYES, UNDERWATER.

The Reach Bravo Wrist Camera gives operators clear vision at the end-effector of their manipulator. Situated just before the wrist rotate stage, this module is a must for complex intervention and inspection, augmenting the vision provided by the vehicle camera. Improve operator situational awareness and improve task accuracy and efficiency.

- ELECTRICAL

COMS	Ethernet (RTSP Stream)
Voltage	12-48V

- ENVIRONMENTAL

Depth	300MSW
Temp	-10°C to 35°C
Material	AL6061

- FEATURES

- 1080p Resolution
- 2MP IP Camera
- High performance in low light conditions
- 2.8mm Standard Focal Length
- 130° FOV
- Minimum Illumination (LUX): 0.01
- Latency: <200ms

NOTES

- Recommend 100Mbps or higher bandwidth
- Reach Bravo must be connected via ethernet to access video feed.

A Revolution for Subsea Inspection & Intervention



Responsive
Integration Support



Responsive
Remote Support



12 Month
Warranty



Ext. Warranty, Spares
Packages & Service Plans
Available



1000+ Hours
Logged