

ALPHA 5 INSPECTOR

A remote multi-sensor measurement tool



Inspect With Ease

The Alpha 5 Inspector is a tough, reliable, intuitive to control manipulator for conducting remote visual and non-destructive inspections.

With high accuracy joint positioning (0.1°) and a master/slave topside controller, the Alpha 5 Inspector is designed to manipulate UT, CP, or other visual/NDT probe heads into position for accurate measurements.



— All Electric

Note: Probe head not included

FEATURES

- Fits on very small ROVs and Crawlers
- Quick to integrate
- Probe Holder Available for your Probe Integration, or
- Build-your-own Probe Holder
- Embedded controllers - no additional POD
- Self-protection against collision
- One-click stow/deploy position
- Corrosion and scratch resistant anodized aluminium
- Advanced monitor software interface
- Data-logging for probe location



— ROV and Crawler Proven

Master Controller Enabled

- ◀ **TOUGH**
300m Depth Rating
Field Proven
- ◀ **USABLE**
Intuitive Interface
Master Arm Controlled
- ◀ **ADVANCED**
0.1° Joint Accuracy
Kinematics and Self-Protection



Note: Master Arm not included

A Revolution for Subsea Inspection & Intervention



Responsive Integration Support



Responsive Remote Support



12 Month Warranty



1000+ Hours Logged



Extended Warranty, Spares Packages & Service Plans Available

SPECIFICATIONS

Reach	0.4m & up depending on probe length
Outer Diameter	40mm
Standard Connector	Teledyne 6 Pin IE(W)-55 Impulse Connector (whip included)
End-effector Accuracy	<1cm
Operator Control Options	3D Space Mouse, Gamepad, Software GUI, Master Controller

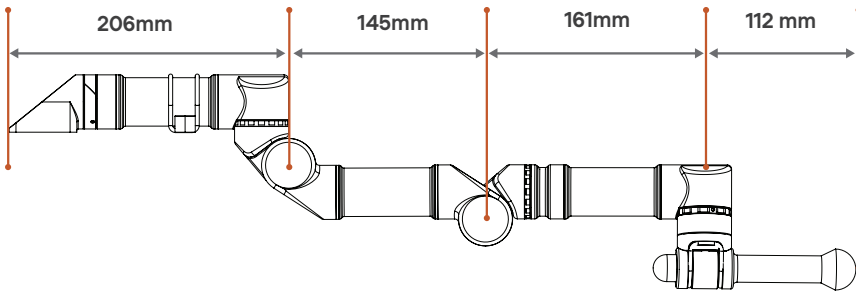
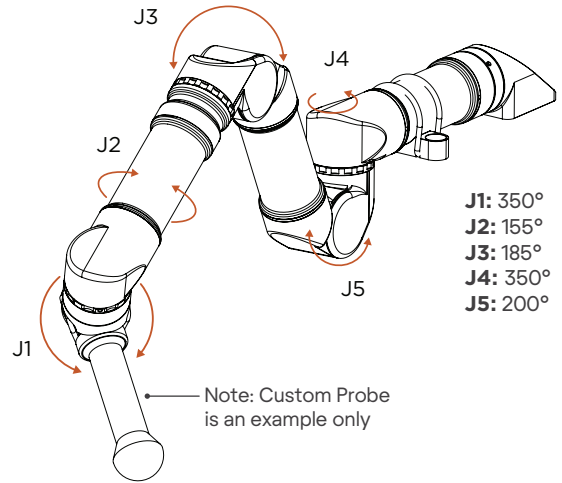

ELECTRICAL

Voltage	18-30V
Wattage	35W Max
COMS	RS232/485

ENVIRONMENTAL

Depth	300MSW
Temp	-35°C to 35°C
Material	AL6061

MECHANICAL

Payload Capacity	2kg
Weight (Air)	1360g
Weight (Water)	900g

High Mobility & Compact

Note: base joint is software limited to 352° (not continuous)

TOP VIEW

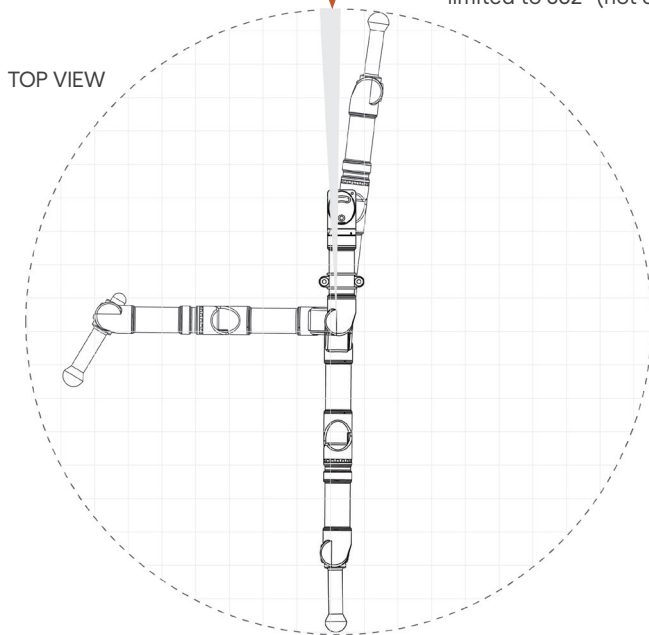

SIDE VIEW

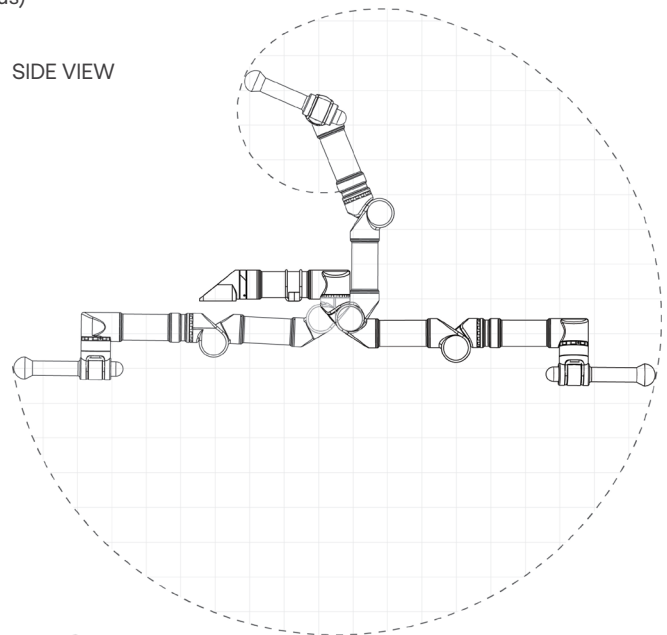

Interface with a variety of industry standard payloads

ACFM

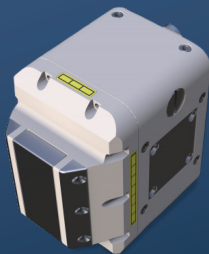

UT + CP Probe



Micro IP Camera

